

# GV2k4

vertical form fill seal machine

Automatic vertical form fill  
and seal packaging machine

Suitable for packing confectionery,  
fresh and frozen foods, granules,  
liquids, pulses, cereals, electrical  
and pharmaceutical products,  
coins and hardware components.

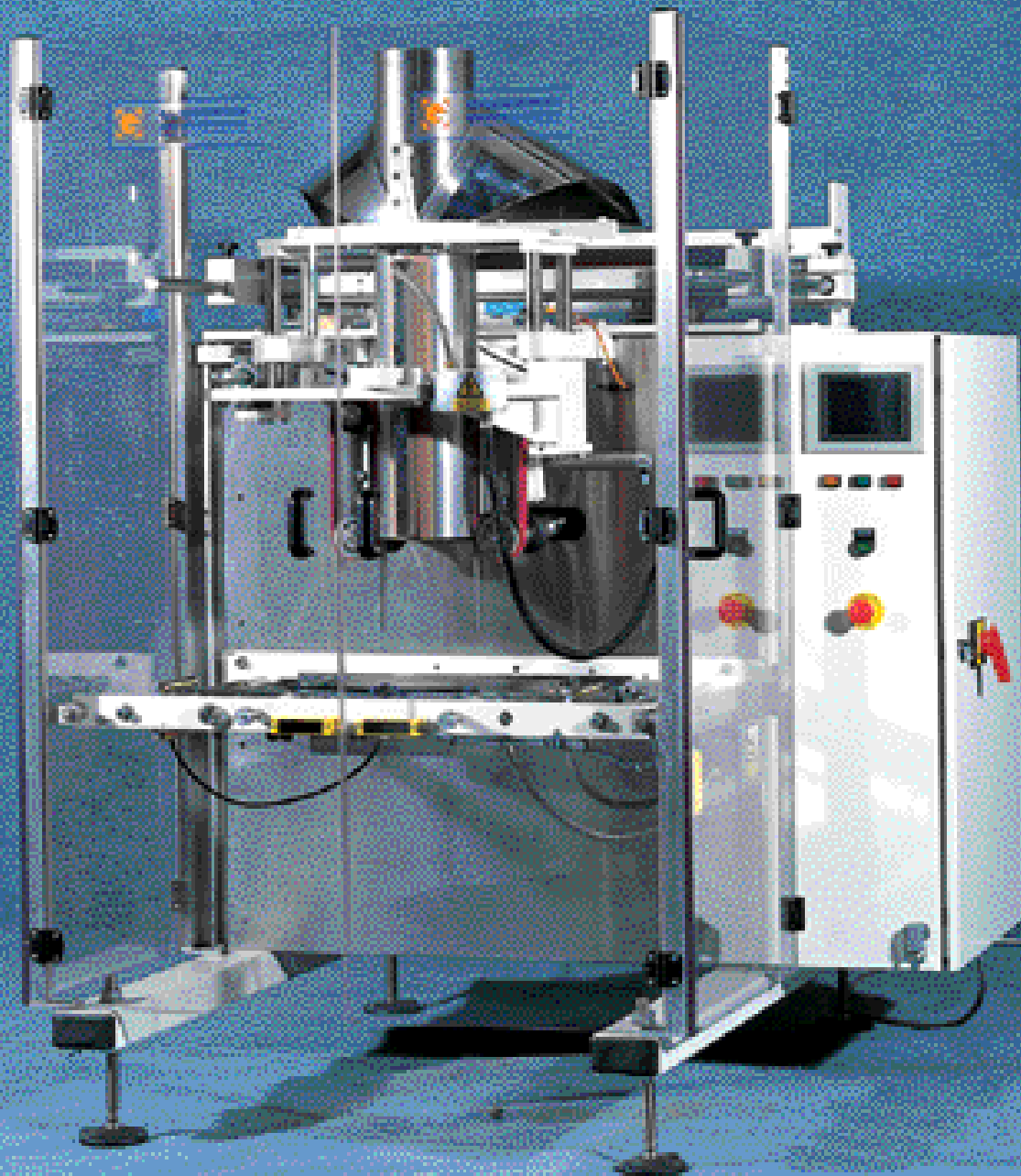

**GAINSBOROUGH  
ENGINEERING COMPANY**  
AUTOMATIC PACKAGING MACHINERY ENGINEERS

Long Wood Road  
Corringham Road Industrial Estate  
Gainsborough Lincolnshire UK DN21 1QB

Telephone ++44 (0)1427 617677  
Facsimile ++44 (0)1427 810443  
Email [sales@gains-eng.co.uk](mailto:sales@gains-eng.co.uk)  
Website [www.gains-eng.co.uk](http://www.gains-eng.co.uk)

# GV2k4

vertical form fill seal machine

## General Description

Manufactured in our Gainsborough factory the GV2k4 packaging machines feature full programmable prologic control of all GV2k4 machine functions - bag length, print registration, over printer, product call and no product - no bag.

The PLC also monitors jaw obstructions, film breakage, packaging material run out and safety guard circuits.

CE certified.

## Features

- Option of painted or full stainless steel frame, parts and bearings, except where weight dictates use of anodised aluminium and bought in items are not available in such materials. (Usually specialist electrical or pneumatic items).
- Heat sealable jaws running on hardened shafts and linear bushes for long and trouble-free life.
- All product contact parts stainless steel.
- Mechanical/inverter/clutch brake controlled intermittent film drive.
- Belts with encoder feed back for measurement of length of pack.
- Industry standard 'brand' named products used when not manufactured in-house.
- Touch Screen PLC control of all machine functions with product codes for ease of product changeovers.
- Photo-electric cell registration.
- Film run out detection.
- Jaw obstruction detection.
- Totalising/batch counting facility.
- Interfaces easily with auger, weighers, liquid and counting systems.
- Machine options:
  - Gussetting
  - Block bottom
  - Bag supports
  - Gas flushing
  - Static eliminators
  - Hole punch
  - Euroslot
  - Overprinting
  - Labeller
  - Take away conveyor
  - Rotary table

## Technical Features

Packing speeds up to 80/minute subject to suitability of packing material feed system and type of product to be packed.

Maximum pack size 250mm wide x 320mm long.

Minimum pack size 80mm wide x 80mm long.

Double bag length facility available. (Subject to suitable bag discharge arrangements).

Low product drop for fragile product.

### Machine dimensions:

Width	1300 mm
Height	2000 mm
Deep	1950 mm
Weight	650kg
Air supply	80psi, 5 bar
Air Consumption	20 - 25 cu ft min, 560 - 700 litres/min.

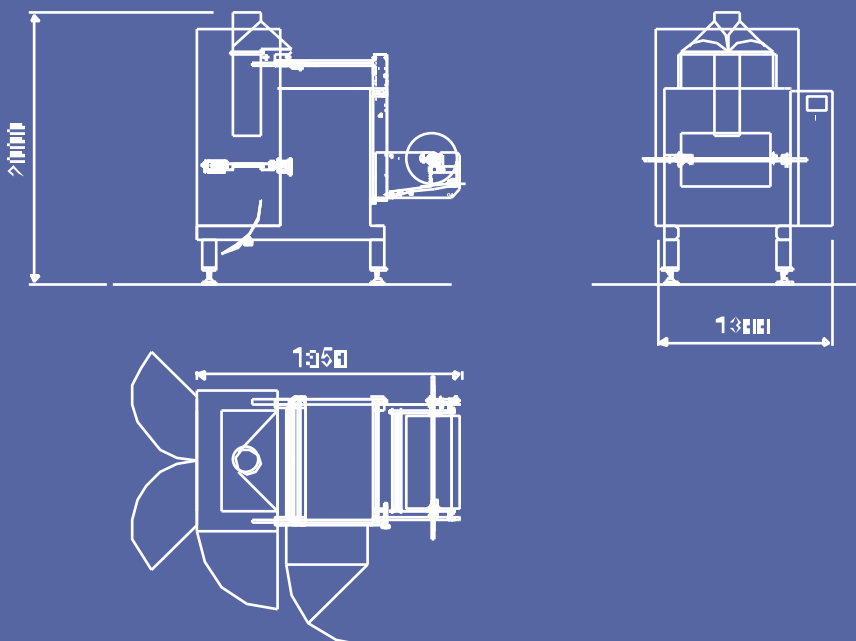

**GAINSBOROUGH  
ENGINEERING COMPANY**  
AUTOMATIC PACKAGING MACHINERY ENGINEERS